

Low-Earth Orbit Satellite Positioning System With Remotely Controlled On-Board Clocks

Fabrizio TAPPERO[†], Andrew DEMPSTER[†], Toshiaki IWATA[‡], Paolo TORTORA[§]

[†] School of Surveying and Spatial Information Systems
University of New South Wales
Sydney, 2052, Australia.

[‡] National Institute of Advanced Industrial Science and Technology (AIST)
Tsukuba, Ibaraki 305-856, Japan.

[§] DIEM - II Faculty of Engineering
University of Bologna, Via Fontanelle 40, Forli, Italy

E-mail: [†]f.tappero@student.unsw.edu.au, [†]a.dempster@unsw.edu.au, [‡]totty.iwata@aist.go.jp [§]paolo.tortora@unibo.it

Abstract. In the present work a new concept of satellite-based navigation system, which does not require on-board atomic references, is presented. This novel concept consists of a constellation of compact low-earth orbit positioning satellites that are equipped with on-board steerable clocks, i.e. voltage controlled crystal oscillator (VCXO). An appropriate ground-satellite synchronization network is responsible for keeping in lock step clocks on-board visible satellites with a master atomic reference located on the ground. Regional/local clock synchronization, low-weight satellites and low manufacturing cost are some of the peculiar aspects of this novel system. Key issues such as number and spatial location of required synchronization stations, clock de-synchronization issues and positioning accuracy are extensively discussed. A software simulator specifically developed for studying its feasibility is also presented together with a plan to develop a micro-satellite payload to demonstrate the feasibility of such system.

Keywords: GNSS, LEO, Synchronization, Atomic Clock, Time Keeping System.

1. Introduction

Currently, the only fully operational Global Navigation Satellite System (GNSS) is the Global Positioning System (GPS), developed by the U.S. in the late 1970s [1]. Developed as a military tool for worldwide positioning, in the early 1980s GPS became widely used in geodesy and surveying. Following the declaration of final operational capability in 1995, GPS was then embraced by the marine, aviation and land navigation communities. **When GPS was conceived, the most difficult technological problem facing the developers was the need to fly accurate timing standards ensuring that all satellite clocks remained synchronised to a single time reference** [2]. GPS uses the one-way ranging principle based on comparing the time-of-transmission of a signal (as determined by a satellite clock) to the time-of-reception (as determined by a ground-based receiver clock), to compute the

time-of-flight of the satellite-to-receiver signal. Simultaneous distance measurements (converting time-of-flight to ranges) to four satellites permits the 3D coordinates and the receiver clock error (relative to the synchronised satellite time scale) to be determined to an accuracy of a few meters. Considering that light travels at approximately 3×10^8 m/s, if the system can tolerate an error buildup caused by the on-board clocks of 1.6 m, the on-board clock frequency stability should guarantee a drift of less than 5 ns between periodic upload telemetry, when the (accumulated) clock error can be effectively re-set to zero. For GPS satellites, such an upload can be performed every half day. Therefore the required frequency stability should be about $(5 \times 10^{-9}) / (4 \times 10^4) = 1.25 \times 10^{-13}$ over 12 hours [2,13]. Such a stringent requirement can be met only by atomic clocks such as cesium and high quality rubidium frequency standards. Figure 1 shows how this requirement appears in the Allan Variance frequency stability plot.

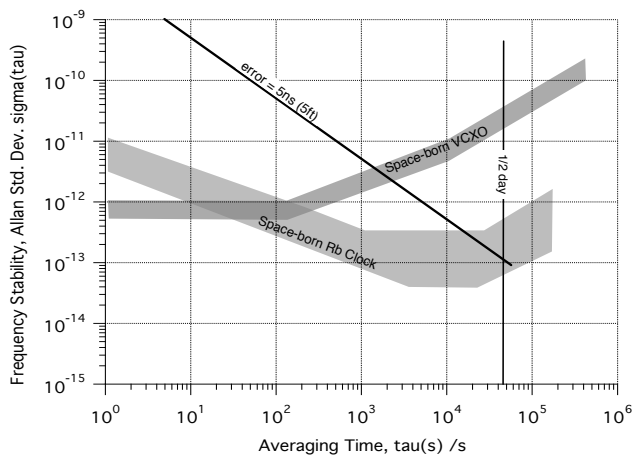

Figure 1. Frequency stability of typical space-born Rubidium (Rb) atomic standard and a space-born VCXO. The oblique line represent the 5 ns timing error, relative to a 5 ft (about 1.5 m) positioning error.

20 years later, Europe decided to realise its own global satellite-based positioning system that would eventually ensure the reliability of all those applications which currently rely on GPS. On December 28th, 2005 the first GALILEO test satellite was launched. GALILEO is not the only alternative satellite positioning system; in fact Russia's GLONASS provided an alternative GNSS. This system was only fully operational for a short period in the mid-1990s, but in the last few years GLONASS has been progressively revitalised. Both GLONASS and GALILEO have the same requirements for accurate clocks as does GPS.

Other satellite-based systems have been designed as regional "augmentations" to GNSS, such as the European EGNOS, the American WAAS and the Japanese MTSAT. In these cases, their main objective is to provide GPS with the integrity to be used for aviation applications such as en-route and terminal navigation. Such augmentation systems mimic GNSS and the technology employed for the satellite clock is again atomic clocks. Other regional systems have also been proposed. Some are "stand-alone", such as *Beidou* from China and IRNSS from India. The Japanese QZSS is a regional system which aims to provide extra "GPS-like" satellites to users in Japan.

Generally speaking, the cost of building and launching a satellite is very high, of the order of hundreds of millions of dollars. Often the projected commercial gain does not justify such expense, especially in the case of multi-satellite systems such as global or regional satellite-based positioning systems.

Europe is pioneering civil-use satellite-based positioning with the launch of the first satellite in December 2005 [3]. China also announced recently (December 2006) that it will build its own system known as *Compass*. Recent publications

have begun to consider new ways to build cheaper satellite-based positioning systems using smaller and lighter satellites [4,5]. This would reduce the huge costs associated with building and launching complex and heavy payloads/spacecraft.

Modern rocket launch costs run into thousands of US\$ per kg for transfer to low-earth orbit, and of the order of twenty thousand US\$ per kg for transfer to geosynchronous orbit. For example, each GALILEO satellite will carry two Rubidium Atomic Frequency Standards (RAFS) and two Passive Hydrogen Masers (PHM) for a total weight of about 36 kg (3.3 kg for each RAFS and 18 kg for each PHM). Hence the launch costs for just the satellite clocks (34 satellites) is about US\$ 24 million. (Note that this ignores the cost of launching all the other satellite subsystems.)

2. An augmentation system with no on-board atomic clocks.

The Japanese Quasi-Zenith Satellite System (QZSS) represents an innovative satellite system design that is able to provide positioning for mobile users over Eastern Asia and Australasia. The integration of QZSS with the present GPS and the planned European GALILEO will improve accuracy, availability and capability over a wide area [6]. Since 2003 the Space Technology Group in the National Institute of Advanced Industrial Science and Technology (AIST) of Tsukuba, Japan, has been studying the feasibility of a new time synchronisation system for QZSS [5]. The novelty of this proposal is the QZSS orbit design and on its high satellite visibility. Such a peculiar feature makes it possible to recast the classic on-board atomic clocks scheme as a remote synchronisation system where the main time reference (atomic clock) is located on the ground in the control station, and a correction/synchronisation infrastructure keeps the on-board time reference continuously aligned with a high accuracy time scale. The main objective of the AIST project is to assess the feasibility of a low-cost on-board clock which would reduce manufacturing costs of QZSS satellites and spacecraft launching costs [7]. As a result of a collaborative research program, the Space Technology Group of AIST, Japan, and the University of New South Wales, Australia, are investigating the feasibility of a remote synchronisation scheme for the QZSS [8].

A concrete implementation to realize this synchronization technology for QZSS is shown in Figure 2. The idea is based on the compensation of the ground station satellite delays through prediction. The precise time available at the ground

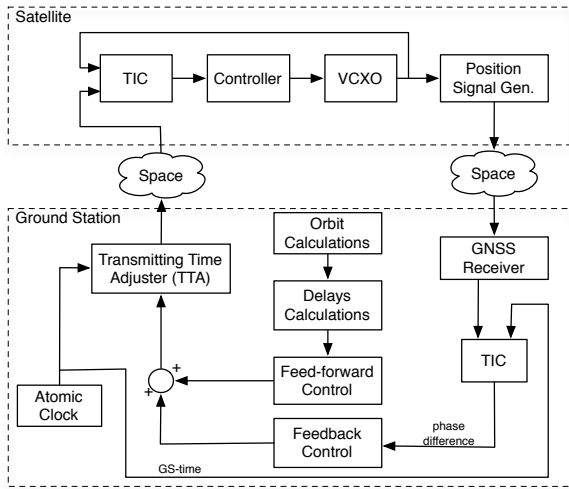

Figure 2. Remote synchronization system for the Japanese Quasi-Zenith Satellite System (QZSS).

station (QZSS-time) is “advanced” by means of the Transmitting Time Adjuster (TTA) and then uploaded to the satellite. Here, a PLL architecture is implemented to steer the local on-board clock, a VCXO, and keep it locked to the received signal. The output of the VCXO is used to construct the QZSS positioning signal that is then broadcast to the user. The key point is to keep the ground station clock and the on-board VCXO synchronized by controlling the TTA such that all communication delays are compensated. To do this, a double feedback and feed-forward control loop, based on orbit prediction and delay calculation, are used. A detailed description of this method can be found in [5,9].

3. Regional Synchronised GNSS

The concept behind the synchronization schematic of Figure 2 could be extended to a worldwide positioning system. The system will rely on a ground-satellite synchronisation network which keeps on-board steerable satellite clocks aligned with a master clocks located on the ground. To achieve opportune synchronisation, satellites have to be visible to ground stations, which are distributed over the territory in where satellite-based positioning is required. The system is a *regional* satellite system with the capability of providing coverage in other regions/countries, as long as a synchronisation ground station network is available and enabled to control the satellites.

3.1 Orbit Design and LEO Satellite Visibility

A satellite system which does not require atomic clocks could be implemented with compact LEO satellites, as proposed in the 2006 by Der-Ming Ma in [4]. The coverage

of the system will depend on the number of satellites and on the design of the orbit. Furthermore, being this system ground-synchronized, the number of ground stations plays also an important role.

When a user tries to get positioning, his receiver will attempt to get signals from all satellites in view at that given location. Thus, satellites visible to the user will need a coherent on-board time. A network of ground stations will guarantee the correct synchronization of all satellites visible in the area of interested. To do this, ground stations have to be properly disseminated over the territory.

To have an idea of the number of needed ground stations and their locations, let’s consider the Australian territory. The Australian continent is roughly a rectangle 4000 Km wide by 3000 km high centered 26.19 deg South and 134.56 deg East. Let’s assume we want to guarantee positioning service for the whole Australian continent. Let’s also assume 4 ground stations, located one for each corner of this hypothetic rectangle. Any user near the ground station will roughly see as much satellites as the ground station therefore clock synchronization of satellites over the ground station does not constitute a problem. However, moving away from it, satellite visibility could be an issue. With the simple geometry considered here, the most critical point is the synchronization of satellite located above the center of the rectangle. Figure 3 shows a simplified 2D representation of ground station, user and the satellite. The formula that gives the length of the path between the satellite and the ground station is:

$$l(t) = \sqrt{(R_{GS} + h)^2 + R_{GS}^2 - 2R_E(R_{GS} + h)\cos\omega t}$$

When the user is between two ground stations, the satellites at the Zenith, for the user, are the most difficult to see for the ground station. In that case:

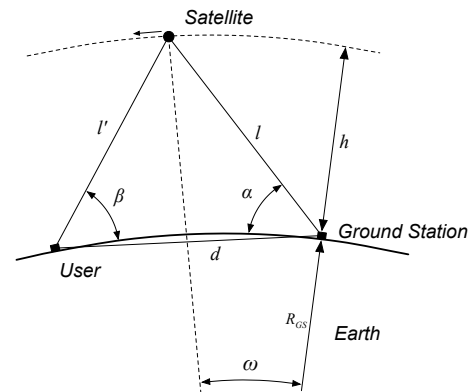

Figure 3. Simplified bi-dimensional representation of synchronization ground station, user and satellite for the proposed system.

$$\beta = \pi/2, \quad \tan(\alpha) = \frac{l'}{d}$$

Considering that the typical orbit of a LEO satellite is about 800 km, if we assume that ground stations are roughly located 4000 km apart, the visibility of satellites which are at the Zenith of the user in between two ground stations is guaranteed by:

$$\alpha = \arctan\left(\frac{l'}{d}\right) = 21 \text{ deg}$$

This means that each ground station would be geometrically able to take care of the synchronization of all satellites located in 2000 km radius and elevation greater than 21 deg. Furthermore, assuming a cut off angle of 15 deg, ground station synchronization capability is guaranteed even further and on a larger area. Therefore with a territory as vast as Australia, the number of ground station could be as small as four.

Advantages of the Proposed System

The concept of a GNSS with no on-board atomic clocks would offer several advantages over the current designs in term of satellite cost, life expectancy and satellite power consumption. This concept could be advantageously applicable to low earth orbit, micro-satellite-based positioning systems, where satellite weight is clearly a critical issue.

The proposed satellite system will be synchronised by an Australian ground segment, so the system will initially work only in Australia. However, as the satellite system orbits about the earth, Australia will be able to eventually provide such functionality to other countries, that by themselves would not have the capability of building a satellite-based positioning system.

With a proprietary satellite-based positioning system Australia would be independent of the U.S. military or European civilian GNSS operators, and hence have access to a positioning system even if GNSS services were not available.

Beside the economic benefits mentioned above, a LEO satellite-based positioning system which does not require a high quality on-board atomic frequency standard is in itself a very interesting system, both from the research and the engineering points of view. Such a revolutionary system may lead to research achievements that could have applicability in

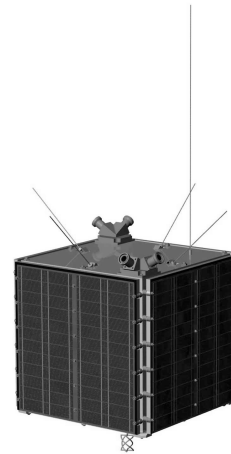

Figure 4. Drawing of the microsatellite ALMASat-I developed by the microsatellite laboratory, in the II School of Engineering, University of Bologna, Italy.

fields such as clock design, network synchronisation and time transfer.

4. Experimental Synchronisation Payload

4.1 Host Satellite, ALMASat-I

The University of Bologna, Italy, has been active in the research field of microsatellite design, manufacturing and operations in space since 2003 [10]. The very first step for the setup of this activity at the microsatellite laboratory located in the II School of Engineering in Forlì was the design, assembly and integration of a fully automated amateur-radio ground station, at first working only at VHF and UHF bands. In 2005 the ground station was upgraded to S-band downlink capabilities, enabling the reception of spacecraft (S/C) signals at higher data-rates (up to 153600 bps). Since then, the ground station has been fully operational and routinely used for the downlink of amateur radio satellites telemetry information, earth images, and store-and-forward packet communication.

In early 2004, the same group of faculty, PhD, graduate and undergraduate student started the design of a low-cost, highly modular microsatellite platform. The S/C was later named ALMASat (ALma MAter Satellite), after the Latin name of the University. The first prototype of this microsatellite platform, ALMASat-I, is planned for launch in early 2008 and will qualify all S/C subsystems for the flight in space.

Most of the engineering solutions adopted for ALMASat-I have been already described elsewhere [10,11,12]. Here we summarise only the most significant characteristics, functional to describe its potential application as the carrier bus for the GNSS payload described above.

ALMASat-I is a three axis stabilized cubical S/C, weighing about 12 kg, whose dimensions are 300×300×300 mm (see Figure 4). Its structure is made of six stackable shop-machined Al trays, each containing a single subsystem. The lower tray (the one pointing toward the Earth) contains the S-band subsystem and the on-board power control electronics. The second tray carries the Attitude Determination and Control System (ADCS) while the third is devoted to the micro-propulsion (fluidic and control electronics). The upper two trays carry the on-board electronic systems (modem, telemetry and on-board computer and the VHF-UHF receivers and transmitters, respectively). The fourth tray, ideally left unoccupied for possible payloads, is filled with the Li-Ion battery packs for the first mission, in order to avoid the S/C to be unbalanced in terms of position of the centre of mass and moments of inertia. Digital information is exchanged throughout the S/C by using a CAN (Controller Area Network) bus protocol, which easily allows the introduction of new systems and electronic boards without the need for changes to the overall architecture.

The modular architecture of the ALMASat bus easily allows its adaptation to payloads with different needs in terms of mass, size and necessary power. Hence, the idea is to consider it as the baseline bus for the on-board remote clock control experiment. Actually, once the GNSS payload characteristics will be fully specified, it will be clear if the nominal size of 300×300×50 mm of a single tray will suffice to host the flight hardware of the navigation experiment. In case more space will be required, the S/C size can be easily increased in height by adding as many trays as needed or, alternatively, increasing the height of the single payload tray. As far as the on-board power is concerned, low-cost Si cells are being used for the ALMASat-I mission but more efficient and reliable triple-junction Ga-As space qualified cells can be used for the ALMASat mission carrying the navigation payload, if needed. Last issue to be considered for hosting the GNSS payload, strictly connected to its interaction with the ground infrastructure, is the amount of data to be exchanged during the ground station contact. At the moment, the combination of the ground station installed in Forlì and the flight hardware installed on-board the ALMASat-I mission allow data rate, at S-band, in the order of 112 kbps. The development of a X-band communication system has already started in the microsatellite laboratory Forlì; the goal is to obtain a system capable of downlink data rates up to 1 Mbps from LEO, thus able to fulfill the most stringent requirements in terms of on-board data volume generation.

4.2 Payload and Ground Station Synchronization Test

For a LEO satellite orbiting at a nominal altitude of 800 km, the maximum visibility time to a ground station is in the order of 15 minutes. This was computed assuming a perfect zenith pass over the ground station and a zero-elevation limit. By assuming non-zero mask angle (say in the order of 5-10 deg, to avoid excessive contamination from ionospheric and tropospheric effects on signal propagation) and a non-zenith pass, the contact time to the ground station reduces drastically. A typical nominal contact time of no more than 10 minutes has to be expected. Thus, the design of the payload-to-ground station synchronization tests must take into account these constraints. In particular, a highly automated acquisition sequence for the payload signals transmitted to the ground must be envisaged, as well as an automated reply from the ground station which will start transmitting its synchronization signals to the on-board clock, to keep it locked to the atomic clock connected to the ground station electronics. If more than a single ground station will be available for the real on-orbit tests, hand-over procedures must also be studied, implemented and tested. As a reference, one could make use of the procedures already successfully used for the hand-over of uplink signals to a distant deep-space S/C, being tracked for navigation purposes by two deep-space stations on Earth. In particular, when (under the effect of the Earth rotation) a ground station loses visibility of the S/C, it must cease transmitting its uplink carrier frequency, as the transmission will start from another ground station in plain view of the S/C. Similar procedures must be studied for the GNSS payload described above, in order to avoid a synchronization signal to be simultaneously received on-board, as transmitted by two ground control stations.

5. Conclusions

In this paper, a new regional satellite-base positioning system which does not require on-board atomic reference has been presented. The satellite can provide the positioning service as GPS. A network of ground stations is responsible for the synchronization of the flying clocks. The synchronization scheme proposed for this system is a modified version of the one proposed in [5,8] specifically made for QZSS. Considering the Australian continent, and considering a LEO satellite GNSS constellation, the minimum number of ground stations is four. Optimum orbit design and ground station dissemination is now under study. Future plans

of testing the satellite on-board clock and ground station clock synchronization scheme on space, have been considered. The microsatellite ALMASat, under development in the University of Bologna, represents a good in-space testbed for a simplified version of the GNSS synchronization scheme suitable for this GNSS system.

References

- [1] http://en.wikipedia.org/wiki/Global_Positioning_System
- [2] Global Positioning System: Theory and Applications Volume I, Bradford, W., Parkinson, J.J., Spilker, Jr., AIAA, (1996).
- [3] http://en.wikipedia.org/wiki/Galileo_positioning_system
- [4] Regional positioning system using low earth orbit constellations, Der-Ming Ma. Acta Astronautica. 2006, vol. 58, pp 387-394.
- [5] Proposal for a Novel Remote Synchronization System for the On-Board Crystal Oscillator of the Quasi-Zenith Satellite System. F. Tappero, T. Iwata, A. Dempster, M. Imae, T. Ikegami, Y. Fukuyama, A. Iwasaki and K. Hagimoto. Navigation. 2007 In press.
- [6] QZSS - Japan's New Integrated Communication and Positioning Service for Mobile Users, Petrovski IG et al., GPS World, 2006, vol. 14, n.6, pp 24-29.
- [7] Space-Based Positioning And Augmentation System With No On-Board Atomic Clocks. F. Tappero, A. Dempster, T. Iwata. Coordinates. Vol 2, Issue 6, pp 26-28, June 2006.
- [8] Remote Control System for the Quasi-Zenith Satellite Crystal Oscillator Based On the Two-Way Time Transfer Method. F. Tappero et al., International Global Navigation Satellite Systems Society. IGNSS Symposium 2006 Holiday Inn Surfers Paradise, Australia, 17-21 July 2006.
- [9] Simulation and Ground Experiments of Remote Synchronization System for Onboard Crystal Oscillators of Quasi-Zenith Satellites. T. Iwata, F. Tappero, M. Imae, T. Suzuyama, H. Murakami, Y. Kawasaki, N. Takasaki and A. Iwasaki. Navigation. 2007. In press.
- [10] The Microsatellite Research Program at Università di Bologna, P. Tortora, E. Troiani, Acta Astronautica, Vol. 56, No 7, 2005, pp. 641-704
- [11] E. Troiani, P.Tortora, G.Piraccini, M.Tappi, "Finite Element Modelling for Static and Dynamic Analyses of a Low-Cost Microsatellite Platform", Paper IAC-04-I.P.05, 55th International Astronautical Congress, 4-8 October 2004, Vancouver, Canada.
- [12] P. Tortora, F. Antonini, G. Vezzali "Design And Testing of Charging Control Circuits for Commercial Li-Ion Batteries with Application to Spacecraft Power Storage", Proceedings of the Seventh European Space Power Conference, Stresa, Italy, 9-13 May 2005 (ESA SP-589).
- [13] The Time Keeping System for GPS Block-IIR, Rawicz, HC et al. (1992), 24th Annual Precise Time and Time Interval Meeting, pp. 5-16.
- [14] Ground Tested for Quasi-Zenith Satellite Remote Synchronization System for On-Board Crystal Oscillator. T. Iwata et al., 24th ISTS, International Symposium on Space Technology and Science, May 30th 2004, Miyazaki, Japan.
- [15] Hardware Experimental Setup for the Remote Synchronization System of On Board Crystal Oscillator. F. Tappero et al., Symposium. on Space Technology, November 4th 2004, Fukui, Japan.
- [16] Software development for the remote Synchronization System of Onboard Crystal Oscillator. A. Iwasaki et al., Symposium on Space Technology, November 4th 2004, Fukui, Japan.
- [17] Research on Remote Synchronization System for Onboard Crystal Oscillators of Quasi-Zenith Satellites. T. Iwata et al., GNSS 2004: The 2004 International Symposium on GNSS/GPS, Sydney, Australia 6-8 December 2004.
- [18] Control Algorithm of the Hardware Simulator For a Remote Synchronization System for the Japanese Quasi-Zenith Satellite System. F. Tappero et al., ION NTM 2005 Conference, January 24-26, 2005, in San Diego.
- [19] Computer Simulation of Remote Synchronization System of Onboard Crystal Oscillators for Quasi-Zenith Satellites. T. Iwata et al., 56th International Astronautical Congress, IAC 2005. 17-21 October 2005, Fukuoka, Japan.
- [20] Positioning Performance Evaluation of the Remote Synchronization System RESSOX for the Japanese Quasi-Zenith Satellite System. F. Tappero et al., GPS/GNSS 2005, 8-10 December 2005, Hong Kong.
- [21] Ground Control Of Remote Synchronization System For Onboard Crystal Oscillator Of Quasi-zenith Satellites. T. Iwata et al., 25th ISTS June 4-11 2006, Kanazawa, Japan.
- [22] Design of Tools and Plan for Remote Synchronization System for Quasi-Zenith Satellites. T. Iwata et al., IGNSS Symposium 2006 Holiday Inn Surfers Paradise, Australia, 17-21 July 2006.
- [23] Anomalies Influence Analysis of the Remote Synchronization System RESSOX for the Japanese Quasi-Zenith Satellite System. F. Tappero et al., 57th International Astronautical Congress, IAC, 2-6 October 2006, Valencia Spain.
- [24] Ground Experiments of Remote Synchronization for Onboard Crystal Oscillator of Quasi-Zenith Satellites - Use of Multiple Positioning Signals for Feedback Control. T. Iwata et al., 38th PTI Systems and Applications Meeting, 5-7 December, 2006. Reston, Virginia, US.