



**International Global Navigation Satellite Systems Society
IGNSS Symposium 2007**

The University of New South Wales, Sydney, Australia
4 – 6 December, 2007

Galileo GIOVE-A Acquisition and Tracking Analysis with a New Unambiguous Discriminator

ABSTRACT

This paper focuses on realizing and designing an unambiguous and cost effective algorithm for tracking a Binary Offset Carrier (n,n) signal such as the BOC(1,1) Galileo signal. The aim of the Galileo receiver design is to acquire and track the E1 band BOC (1, 1) signal broadcast by the prototype Galileo satellite-GIOVE-A. Results show that it can be successfully acquired using a narrowband front end with low sampling rate utilizing conventional acquisition methods. To eliminate the effect of the ambiguous correlation function while maintaining all the features of the BOC (1, 1) spread spectrum signal, a novel non-coherent code tracking algorithm is introduced and two architectures of combining Costas loop and Delay Locked Loop (DLL) are proposed. The performances of different DLL discriminators are compared. The strength of the novel design lies in its low complexity, high robustness and lack of ambiguity with a relative high slope of discriminator function which has flexibility of choosing Early/Late spacing liked a conventional Narrow Correlator and possibility of maintaining the multipath rejection property.

KEYWORDS: Galileo; BOC (N, N); Costas Loop; Code Tracking Discriminator; Delay Locked Loop; Multipath.

1. INTRODUCTION

Many new satellite navigation signals are coming on stream. The first, and, to date, only, prototype European satellite GIOVE-A was launched in December 2005 and has started transmitting E1 and E5/E6 signals since January 2006. The US Global Positioning System (GPS) has had satellites transmitting the modernized L2C signal since 2005. Moreover, Russia's GLONASS and China's "Compass" system are testing new satellite signals. For those applications demanding reliable and precise positioning, GNSS receiver designers are eager to look for solutions to maintain the interoperability between different modern systems.

Meanwhile, the hybrid GNSS receiver has to have low complexity and, practically, should be based on current GPS hardware platforms. As the Galileo E1 band Open Access Service signal is designed to share the same carrier frequency and the same concept of direct sequence code division multiple access (CDMA) system as the GPS L1 signal, a hybrid GPS/Galileo receiver design at the L1 frequency becomes an interesting topic of study. Therefore, the BOC (1, 1) signal processing at L1 is the topic of this paper. For convenience the term -“Galileo signal” is used in this paper for the E1 band BOC (1, 1) signal.

Galileo introduced the innovative signal structure Binary Offset Carrier (1, 1) (or BOC (1,1)), which is aimed to provide the advantages of multipath effect reduction and narrow band interference rejection. However, conventional GPS L1 receiver design techniques and cost effective platforms are designed for a BPSK modulated signal. When the conventional design is adopted by Galileo signal processing, it will experience signal loss because of poor tracking loop (i.e. Delay Lock Loop (DLL)) stability due to 1) the wider main lobe of Galileo signal frequency spectrum 2) the ambiguous secondary peaks on the Galileo signal Autocorrelation Function (ACF). In this paper practical solutions (e.g. acquisition methods and tracking loop algorithms) are investigated for a Galileo receiver with low complexity and high accuracy.

The ambiguity problem of BOC (1, 1) is one of the most challenging aspects for an E1 band Galileo receiver designer. When conventional early minus late DLL discriminators are applied, one stable zero crossing node and two unstable zero crossing nodes (or false steady nodes) exist on the discriminator function (Kovář, *et al.*, 2004). This can affect the precision of hand-over information (e.g. code phase and Doppler frequency bin) from acquisition to tracking. Secondly, it can cause the DLL to lock at the wrong point in the code, reducing signal to noise ratio (SNR) and introducing a large pseudorange bias (Kovář, *et al.*, 2004).

Aiming to avoid the ambiguity of BOC (1, 1), many methods are proposed. However, most of them are either complex in their hardware/software design or reduce the signal performance. They can be generally categorized into 4 types: Self-adjusting method, shaping method, BPSK-like method and BOC-PRN method. The shaping method usually involves weighted linear combinations of several ACF envelopes (e.g. the “Shaping Correlator” (Garin, 2005)) or weighted linear taps of an ACF structure (e.g. methods in (Fante, 2003) and (Castro, *et al.*, 2006)), so that the false steady node of the E-L discriminator function can be “cancelled” out while the multipath mitigation features can be maintained. However, this type of method usually pays the price of a) using a complex hardware structure for getting different correlations simultaneously and b) losing signal sensitivity due to the combination of independent noise sources. The self-adjusting method includes the conventional “Bump-Jumping” (Fine & Wilson, 1999) and extended Kalman filter loop approaches (Nunes, *et al.*, 2004). These techniques, by contrast, take advantage of the secondary peaks to form the so-called very-early (VE) and very late (VL) replicas, cooperating with the conventional early (E), punctual (P) and Late (L), to detect or estimate the correct main prompt position of the ACF. Although these methods can maintain the desired features of the BOC signal, they still require two extra replica code arms for VE and VL. Also, a more complex discriminator algorithm or computation is also needed. BPSK-like methods treat the BOC (1, 1) signal as the modulation of square wave (SW) and Pseudo Random Noise (PRN) and examine one of the two side-lobes (Martin, *et al.*, 2003). The two symmetrical side-lobes of the BOC (1, 1) spectrum appear as BPSK-like components. Treating one side-lobe as a BPSK signal results in a triangular-shaped ACF much like that for conventional GPS C/A code. However, using this technique, signal loss occurs because only one side-lobe is considered and due to the fact that the offset carrier is not sinusoidal. Moreover the robust multipath rejection property of

BOC (1, 1) is lost, which can be expected due to the loss of signal bandwidth. Another novel method is so-called BOC-PRN method. Rather than match a local BOC (1, 1) replica with the received signal, it uses the PRN (i.e. not modulated by the offset carrier) as a local replica to align with the incoming BOC (1, 1) signal, so that a discriminator function similar to a 1-chip spacing standard E-L “Wide correlator” (Van Dierendonck, *et al.*, 1992) function is generated directly from the output of prompt code arm (i.e. removing the conventional “differencing” component of the code phase error estimation). By adding an extra square window (or “gate”) onto the Galileo spreading code, it also claims to be able to maintain the multipath mitigation features of BOC (1, 1) (Dovis, *et al.*, 2005). However the loss of the steep slope of the discriminator function curve can cause increased code phase jitter which decreases accuracy (Dovis, *et al.*, 2005). Moreover, most of above methods are either only designed for coherent discriminators or do not provide practical formula and implementable architecture for DLL, so that it can combine with Costas Loop.

Based on the BOC-PRN concept, a type of DLL that can take the benefit from both I and Q arms of Costas loop is designed and implemented, which is called “BOC-PRN (direct prompt)” in this paper. However, this method has a trade off between complexity and accuracy like the standard BOC-PRN methods. An extended BOC-PRN method therefore has been introduced, which is using early and late correlators added (here called “BOC-PRN (E+L)”). The advantages of BOC-PRN (E+L) lie in the facts that, 1) it has a relatively high slope of the discriminator function; 2) it can provide possible multipath mitigation features like a narrow correlator by having the ability of choosing different E and L spacing, without adding any extra hardware or software.

In this paper, acquisition of the GIOVE-A E1 signal using a GPS L1 front end is introduced in section 2. Different DLL discriminators are given and compared in section 3 for conventional BOC-BOC normalized E-L, BOC-BOC dot product, BOC-PRN direct prompt, and the new BOC-PRN E+L. Results of offline tracking for a set of recorded real GIOVE-A satellite signal data are shown in section 4, and the paper concludes in section 5.

2. ACQUISITION METHOD AND IMPLEMENTATION

Most of the current low cost L1 GPS receivers utilize narrowband (2MHz) front ends with relatively low sampling frequencies. This is sufficient for the acquisition of L1 C/A signal whose spectrum main lobe has a width of about 2MHz. However, the Galileo BOC(1, 1) signal at L1 has double that bandwidth in its two main lobes (i.e. about 4MHz), so about half of its spectrum will be lost when using such a narrowband front end (Qaisar, *et al.*, 2007). As a result, it is necessary to investigate the effect of a narrowband front end on the Galileo BOC(1, 1) signal, as well as the sampling rate, for the purpose of joint GPS/Galileo receiver design at L1.

A series of experiments were carried out using three front end products: the Nordnav R30 software receiver, the SiGe SE4110L-EK3 ser1051 and the Namuru receiver developed by the SNAP at UNSW. Because GIOVE-A is the only prototype Galileo satellite transmitting at the moment, all of the tests were based on the specification of GIOVE-A, whose information is only now available in the ICD (Galileo Project Office of European Space Agency, 2007). Much of the early work was based on the “cracked” codes provided by Cornell (Psiaki, *et al.*, 2006) and Oliver Montenbruck (Montenbruck *et al.*, 2006). As discussed in (Qaisar, *et al.*, 2007) and (Balaei *et al.*, 2007), the minimum integration time can be chosen to be 8ms for the

pilot channel (C channel) and 4ms for the data channel (B channel). Experimental results show that, despite the ACF being “rounded off” after the signal passed through the narrowband front end, it still maintains most of the characteristics of the wideband version (see Figure1 and Figure 2 for the two narrowband receivers).

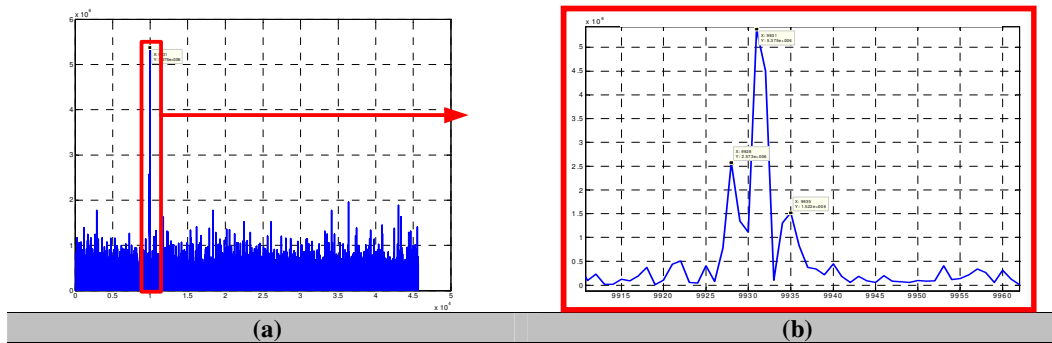

Figure 1 (a)ACF of Primary code in C Channel; (b)Zoom of the Primary code ACF(data recorded using “Namuru” GNSS Receiver at UTC time-5H:17Min , 3rd March 2007, location of observation: 33.5517°S, 151.1340°E).

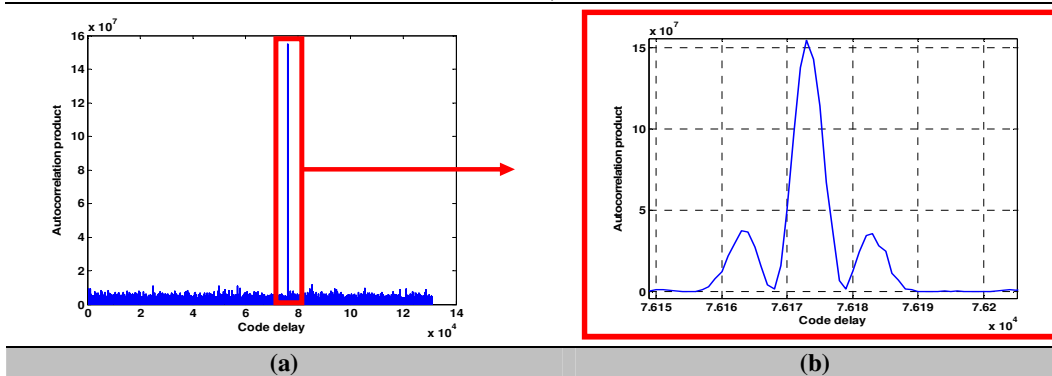

Figure2 (a)ACF of Primary code in C Channel; (b)Zoom in on Primary code ACF(data recorded using SiGe SE4110L-EK3 ser1051 Frontend at UTC-7H:31Min on 30th March 2007, location of observation: 33.5517°S, 151.1340°E).

The main function of the acquisition unit is to acquire and estimate the coarse code delay and Doppler frequency of the satellite signal in a DFT based open loop unit. It then hands over that information to the tracking loop unit for ongoing synchronization with the incoming signal code and carrier. However, unlike GPS C/A code, Galileo BOC(1, 1) has two secondary peaks in its ACF, located at half a chip away from the correct prompt correlation location. The consequences of tracking the incorrect peak are seriously biased pseudorange measurements and lower SNR which will affect tracking. In Figure 1 and Figure 2, both of the Galileo ACFs are obtained using a 2MHz wide front end; with sampling rates of 5.714MHz (Namuru) and 16.3676 MHz (SiGe). The NordNav R30 software receiver also uses a 2MHz wide SiGe front end (different series) with a sampling rate of 16.3676 MHz; acquisition results (slightly better signal quality than the SiGe SE4110L-EK3 ser1051 front end) is shown in (Qaisar, *et al.*, 2007).

By comparing Figure 1 and Figure 2, a low sampling frequency receiver would be more likely to have serious ACF distortion (due to low resolution in time domain) and higher background noise that will eventually handover to tracking loop. Therefore, to enhance the performance of a low cost receiver, it is important to design an algorithm that can optimize the low complexity and high robust characters of the tracking loop.

3. CODE-TRACKING LOOP COMBINING WITH COSTAS LOOP FOR BOC (1, 1)

In a conventional GPS receiver, the Costas loop is used so that the carrier tracking is insensitive to the 180 degree phase change of navigation bit (Borre,*et al.*, 2006). Such a feature is also necessary for Galileo when the integration time (T) is selected to be 8ms for the pilot channel/ 4ms for the data channel. In the data channel, as the navigation bit has an interval of 4ms and is synchronized to its PRN (the B-code whose full code period is 4ms), the phase of any navigation bits change at the tracking loop update interval of 4ms. Similarly, when the update interval for pilot channel is 8ms (the full period of the C-code PRN), the secondary code which has a 8ms period can be treated in the same way as the navigation data as it can cause a phase change at the tracking loop update period. As a consequence, the Costas loop which uses In-phase (I) and Quadrature (Q) will also be a reasonable solution for Galileo signal carrier tracking.

The function of the code-tracking loop is to track precisely and wipe off the incoming modulated code. The “quasi-coherent” DLL discriminator has good performance in terms of phase lock sensitivity and rapid response to phase transitions by considering energy from both I and Q arms (Ward, 1996). Hence, by applying the conventional E-L DLL discriminator, the maximum prompt value of the even ACF can be converted into an odd discriminator function which can be expressed as code phase error (in chips) versus the code delay of the local code replica. In this way, the correct position of the prompt correlator is represented by zero phase error at the centre of the odd discriminator function (shown in Figure 3). However, different from the PRN code for GPS C/A code, which has a triangular shaped ACF, BOC (1, 1), generates an ACF which has two secondary peaks located on either side of the true prompt peak. As a consequence, the E-L DLL discriminator can also come up with two extra zero crossing points as discriminator outputs of zero phase error. Therefore, false stable tracking modes are possible. To solve such an ambiguity problem, different DLL discriminators are investigated in this section.

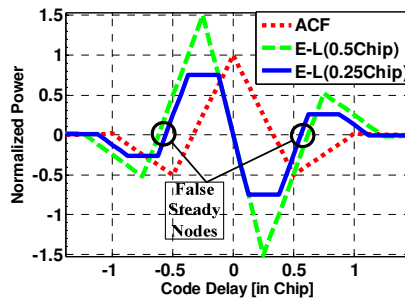

Figure 3 BOC-BOC ACF (red) and the corresponding E-L DLL discriminator function with 0.5chip E/L spacing (Green) and 0.25chip E/L spacing (Blue)

3.1 Analysis of DLL Algorithm for BOC (1, 1)

3.1.1 Conventional BOC-BOC (Early Minus Late)

The Normalized E-L power and Dot Product E-L are commonly used as conventional DLL discriminators in GPS receiver design (Ward, 1996). Although both can be normalized to become insensitive to signal amplitude (Ward, 1996), in some of the commercial GNSS receiver, only the first uses normalization; so the normalized one slightly outperforms the Dot Product E-L discriminator. In general, both can be applied to BOC (1, 1) with an expectation

of lower noise than BPSK ($\sqrt{3}$ times lower) when the same E and L chip spacing is applied, due to narrower ACF (Gerein,*et al.*, 2004). However, because of the ambiguity problem in the BOC-BOC method, the linear operation range of the E-L discriminator has also been reduced to 1/3 of that of BPSK.

3.1.2 BOC-PRN algorithm

To compensate for the limit to the linear operation range, the coherent BOC-PRN discriminator (Dovis,*et al.*,2005) is investigated, which aligns the local PRN with the incoming BOC(1,1), so that a BPSK-like cross-correlation function is produced. To distinguish such a correlation function from the ACF of BOC-BOC (shown in red in Figure 4), it is called cross-correlation function(CCF) in the rest of this paper. The resulting CCF (shown in blue in Figure 4) can be applied as a discriminator function in the DLL directly because it has just one zero crossing in phase error, making it “unambiguous”. The ambiguity of the BOC-BOC discriminator is avoided while maintaining the linear discriminator operational range. The down-side is lower discriminator gain (slope). The slope is lower because such a demodulation method can be regarded as similar to an E-L discriminator for BPSK using a 1 chip E/L spacing. Because of the effective fixed E/L separation, the multipath mitigation properties of techniques such as the Narrow Correlator cannot be achieved. Also, the carrier to noise ratio density(C/No) of the tracking loop will be correspondingly decreased compared to a conventional narrow E-L correlator which is claimed to have better noise reduction when the E/L spacing is further reduced (Van Dierendonck,*et al.*, 1992).

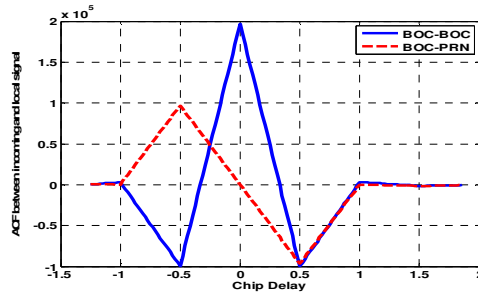

Figure 4 BOC-BOC ACF(Blue)&BOC-PRN CCF(red)

Originally, this standard BOC-PRN discriminator was not designed for a DLL cooperating with a Costas Loop where the carrier tracking loop may not be in perfectly lock. However, taking advantage of a Dot Product E-L discriminator implementation, a new expression is introduced here for a BOC-PRN discriminator. Because the product of the BOC (1, 1) and the PRN can be treated as an expression of E-L, the new expression is formed like a Dot Product E-L expression except that the weight of prompt code is ignored. The expression for such an expression is shown in Eq. 3.1(a) and it is called BOC-PRN (direct prompt) in this paper for convenience; while the expression for conventional Dot Product is shown in Eq. 3.1 (b) (which has multiplied the weight of prompt code with the power difference between E and L) and the Normalized E-L discriminator is expressed as in Eq. 3.1(c):

$$D_1(\tau) = (I_P + Q_P)/F_1 \quad (\text{Eq. 3.1 (a)})$$

$$D_2(\tau) = ((I_E - I_L) * I_P + (Q_E - Q_L) * Q_P) / F_2 \quad (\text{Eq. 3.1 (b)})$$

$$D_3(\tau) = (\sqrt{I_E^2 + Q_E^2} - \sqrt{I_L^2 + Q_L^2}) / (\sqrt{I_E^2 + Q_E^2} + \sqrt{I_L^2 + Q_L^2}) \quad (\text{Eq. 3.1 (c)})$$

, where: τ is the chip delay of local replica;

I_P and Q_P are the estimated maximum prompt of I and Q components;

I_E and Q_E are the estimated x chip estimated Early prompt of I and Q components;

I_L and Q_L are the estimated x chip estimated Late prompt of I and Q components;
 $F1$ and $F2$ are scale factors determined by the signal power and sampling rate so that the code phase error is scaled into reasonable range.

Since the Dot product E-L discriminator function shown in Eq.3.1 (b) has not been inherently normalized, it is sensitive to the change of signal amplitude, as is the new discriminator expression for BOC-PRN (direct prompt) expressed in Eq. 3.1(a). The Normalized discriminator Eq.3.1 (c) is expected to be more robust in terms of rapidly changing SNR conditions (Ward, 1996). Moreover, the gain of the discriminator function is important because it affects the DLL dynamic performance (in terms of resulting code phase error). It is determined by the loop bandwidth which is roughly proportional to the loop gain (Ward, 1996); while for a second order tracking loop, the loop gain is the combination of a first order loop filter and the gain of the discriminator function. To compare the discriminator functions and their corresponding gains using Eqs. 3.1 (a) (b) and(c), their ideal and simulated results are shown in Figure 5 (with E/L chip spacing of 0.3chip).

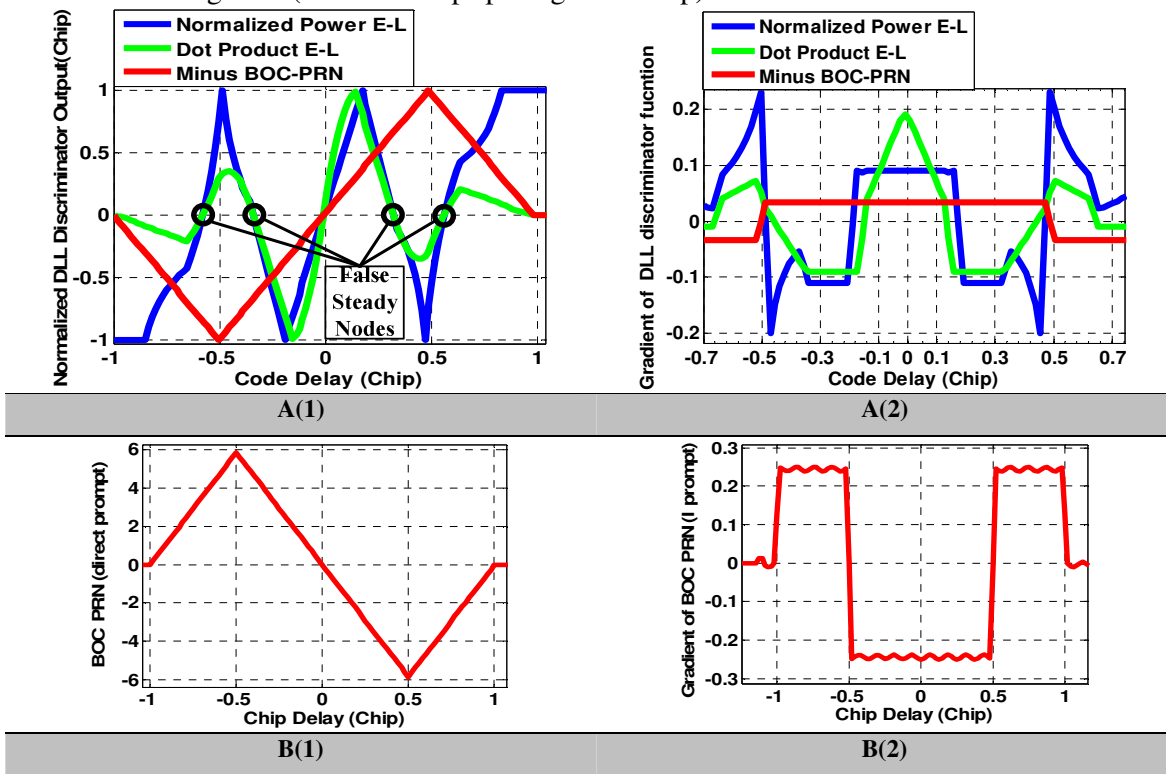

Figure 5 DLL discriminator Functions and their corresponding Gains

A. Ideal normalized discriminators of BOC-BOC Normalized(blue) E-L Discriminator(green) ; BOC-BOC Dot Product E-L Discriminator(red)

B Simulated BOC-PRN Direct Prompt Discriminator (using C-code)

(1)Discriminator function (2)Gain(Gradient) of the Discriminator functions

As shown in Figure 5 A (1) and A(2) the BOC-PRN(direct prompt) has a low but constant gain region three times wider than the Normalized E-L discriminator; while the Dot-Product E-L discriminator has a relative steep slope (i.e. highest gain) around the prompt of the BOC(1,1) ACF and then drops dramatically as code phase error increases. Besides, according to Figure 5 B (1) and B (2), the scale factors in the discriminator expression (Eq. 3.1 (a)) play a role in adjusting the maximum discriminator output (i.e. allowable feedback estimated code phase error in DLL) and the corresponding gain of discriminator function (e.g. reducing $F2$ by n times can lead to n times higher maximum feedback due to code phase error, also increasing

the gain of the discriminator function by n times).

3.1.3 Extended BOC-PRN algorithm

The BOC-PRN direct prompt discriminator has such a relatively low slope which makes it difficult to make a balance between high gain and low feedback code phase error. To compensate for its low slope, novel discriminator architecture is proposed here in which E and L arms are used, similar to the conventional discriminator. However, instead of subtracting these arms, this new discriminator function expression uses E plus L (E+L) so the new expression for discriminator output is:

$$D_4(\tau) = (I_E + I_L + Q_E + Q_L)/F_3; \text{ (Eq. 3.1 (d))}$$

,where F3 is a scale factor also determined by signal power and sampling rate so that the code phase error is scaled into reasonable range. This method is called BOC-PRN (E+L). The corresponding simulated discriminator function and gain is shown in Figure 6 (also with 0.3 chip E/L spacing).

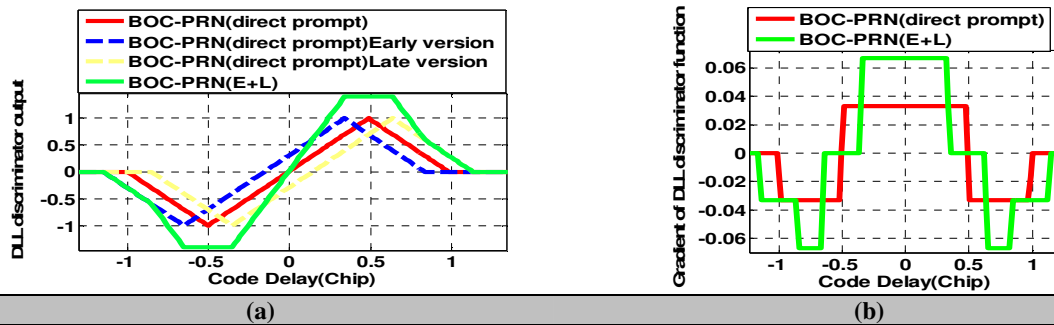

Figure 6 The new DLL discriminator BOC-PRN (E+L) Functions(a) and its corresponding Gains(Gradient) (b)

As can be seen from Figure 6, the BOC-PRN (E+L) discriminator function has twice the slope of the BOC-PRN (direct prompt) although there is a slight reduction in linear operational range (shown in Figure 6(b)) which is also determined by the E/L spacing like that for a standard Narrow correlator. Also, by specifying E and L, the Prompt delay can be estimated by using both E and L arms; while for standard BOC-PRN, there was only one Prompt arm.

One advantage of the BOC-PRN (E+L) is that it has a discriminator function shape similar to that of the E-L discriminator using a Narrow Correlator which has the flexibility of changing E/L spacing. In a Narrow Correlator, the noise components from early and late arms become more and more correlated as the E/L spacing is reduced and hence they can cancel each other out to improve the C/No of the tracking loop (Dierendonck,*et al.*, 1992). The E/L spacing for BOC-PRN (E+L) should thus not be too narrow in order to avoid increasing the power of correlated noise components. The extreme case, when the E/L spacing is zero, gives the BOC-PRN (direct prompt) discriminator function multiplied by two. In that case, the SNR should not have any improvement. On the contrary, when the E/L spacing increases, the independent components of noise can also eliminate each other so that the tracking loop performance improves.

Considering multipath rejection, a wider E/L spacing may lead to better multipath rejection performance. Based on the understanding of applying Narrow Correlator for GPS signal, the shape of the sharp point at the triangle-like ACF is less vulnerable to weaker multipath signal (Novatel Inc., 2000). Likewise, if the BOC-PRN (E+L) discriminator can pick up a wider E/L which are located closed to the two sharp points of the CCF may result in less

pseudorange estimating error. However, the linear operational range of the new discriminator narrows as the E/L spacing increased. The comparison between 0.3 chip and 0.6 chip spacing BOC-PRN (E+L) discriminator functions is shown in Figure 7.

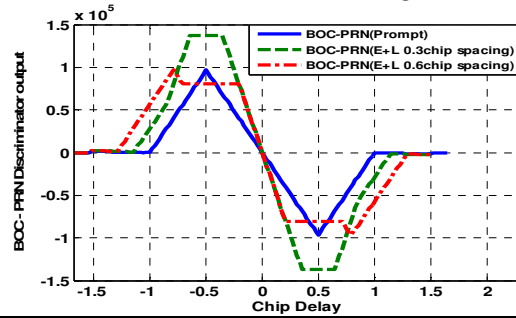

Figure 7 DLL discriminator BOC-PRN (Direct Prompt V.S. E+L) Functions with different |Early –Late| Chip Spacing

3.2 Implementation of Costas Loop Tracking

3.2.1 Tracking loop system architectures

The architecture for (standard E-L) (Ward, 1996) is shown in Figure 8 and two new proposed architectures for two types of discriminator (BOC-PRN (direct prompt) and new BOC-PRN (E+L)) are shown in Figure 9 and Figure 10 respectively.

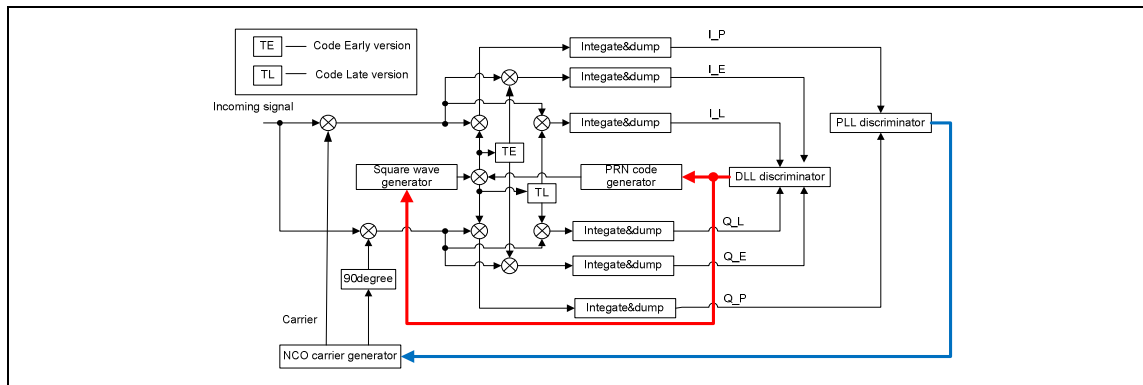

Figure 8 Conventional BOC-BOC (E - L) Costas Loop architecture

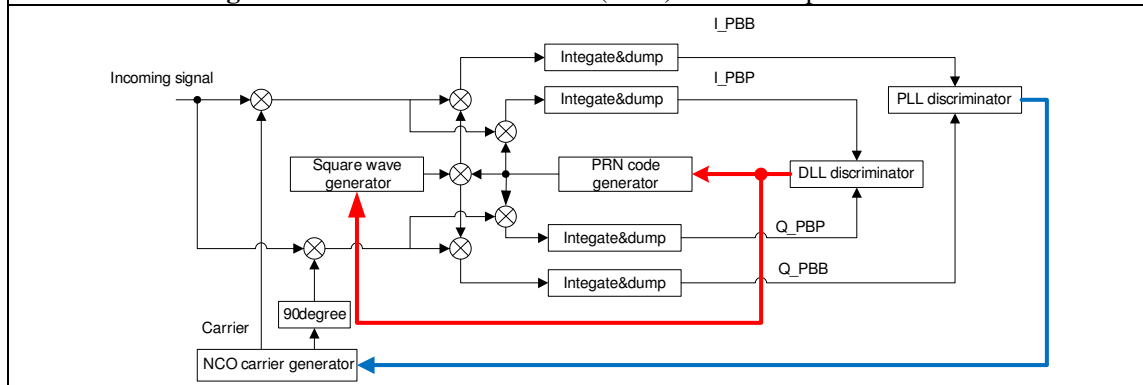
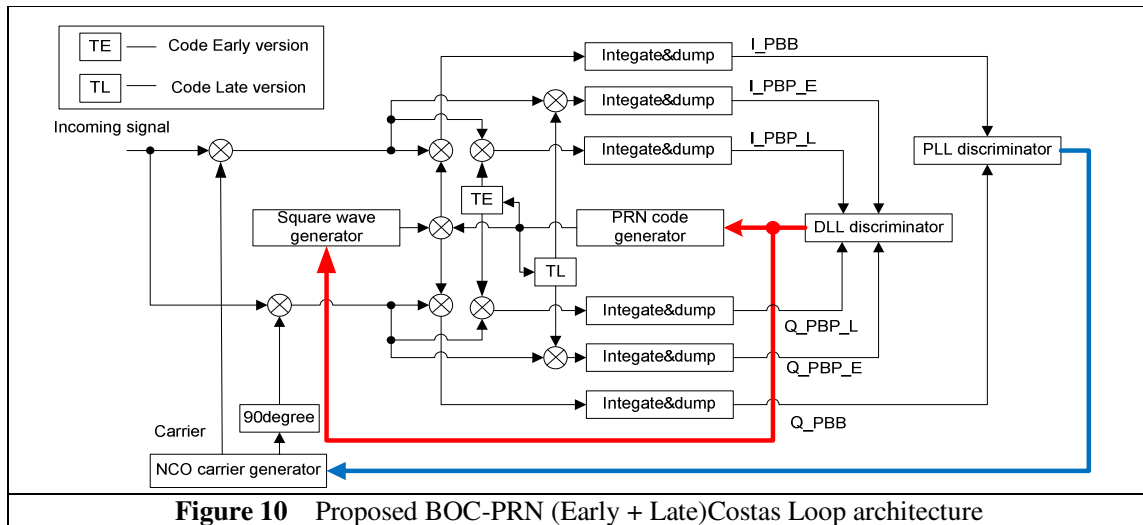

Figure 9 Proposed BOC-PRN (Direct Prompt) Costas Loop architecture



Comparing the hardware complexity of the three architectures, using the same PLL discriminator and different DLL discriminators, the BOC-PRN (direct prompt) is the simplest design. The new BOC-PRN (E+L), uses some extra components to sum the E and L arms; however, has increased the slope of discriminator function and hence improved the code tracking loop performance. The Dot product E-L also requires a multiplication function. The Normalized E-L is the most complex discriminator; however it has the best quality of signal in terms of SNR when tracking (Ward, 1996).

3.2.2 Tracking simulated satellite signals

Experiments tested the performance of the discriminators using two simulated signals. The first is the simulated GIOVE-A C-channel signal, which has the carrier modulated with the C-Code and the subcarrier (including the effects of Doppler). The S-code is ignored, so that the change of code phase due to changing S-code bit at each tracking update interval is neglected and the resulting combined tracking loop (Costas loop and DLL) output is equivalent to a step response of code phase (the code phase of S-code jumps in as a step at the first pull in stage and remains constant at the rest of tracking update intervals). The experimental settings for different discriminators using this signal (marked as state “o”) are shown in Table 1.

The resulting average code phase bias (or mean code error), also shown in Table 1, is the mean of the outputs of the DLL discriminator when tracking using the loop software of “Borre” (Borre. *et al.*, 2006). It shows that the scaling factors (i.e. F1, F2 and F3) can significantly affect the mean value of the code error. This scaling factor can play a more important role in two BOC-PRN discriminators because they are neither inherently normalized according to the varying signal amplitude nor weighted by the Prompt value. The discriminator outputs have to be scaled by a fixed factor so that they can play a role like the normaliser (although it should be varying according to different C/No of incoming signal in an optimized application), in order to control the feed-back value within an reasonable range to keep the DLL in lock. Moreover, the gain (i.e. K_d) of the discriminator also need to be scaled so that it can combine with the loop filter gain (i.e. K_o) to maintain a higher combined loop gain (i.e. K_i) for the dynamic performance in low SNR.

According to the step response of code phase, the combined tracking loop with the BOC-PRN (E+L) discriminator is easier to control (results shown in Table 1). When the scaling factor is too big (e.g. 600E6 for BOC-PRN(direct prompt) and 550E4 for BOC-PRN(E+L)), the

discriminator feeds back a maximum code phase error as small as $5.6E-5$ (for BOC-PRN(Direct Prompt)) or $9E-3$ (for BOC-PRN (E+L)), the gains of the discriminator functions are also reduced with ratios corresponding to the scale factors. Hence with such a low gain of discriminator, the loop is very difficult to converge with a zero phase error. As a consequence, with a lower discriminator slope, the BOC-PRN (direct prompt) discriminator output is more likely to settle to the maximum code error, i.e. 0.5 chip delays from the correct prompt, which is unacceptable. Experimental results however shows that, with the same combined loop gain (K_{ld}) ($=5$), when the discriminator gain of BOC-PRN (E+L) is reduced to an appropriate level (e.g. $5E-1$), the resulting discriminator output successfully settles down to a quite small value (e.g. $<1E-5$) closed to the actual discriminator centre point, compared to the theoretical maximum code phase error (e.g. $=9$); while a DLL with a BOC-PRN (direct prompt) cannot achieve such a performance even when the same settings for BOC-PRN (E+L) are applied.

	BOC-BOC (Normalized E-L)	BOC-BOC (Dot Product E-L)	BOC-PRN (Direct Prompt)	BOC-PRN (E+L)	
Scale factor	1	1/300E6	1/600E6	1/550E4	1/550E1
DLL Discriminator Gain K_d	0.1	5	$2.5E-6$	$5E-4$	$5E-1$
DLL Loop filter Gain K_o	50	1	1500000	100000	10
Loop gain $K_{ld}=K_d*K_o$	5	5	-	5	5
State	* o	* o	o	*	o
Maximum code error(DLL discriminator output)	1	21	$5.6E-5$	$9E-3$	9
Mean(code error) ("o")	0.0001	0.0002	0.000053	0.0090	<0.00001
Costas Loop Setting	E and L distance in chip = 0.3 [Chip] Dll Noise Bandwidth = 4 [Hz] Pll Noise Bandwidth = 10 [Hz] Integration time T= 0.008 [Sec] PLL Loop filter Gain K_{lp} = 0.4;				
State definition	O: without s-code ;No noise *: With S-code and varying noise level				

Table 1 Costas Lock Loop setting for simulated satellite Intermediate Frequency (IF) raw signal

The step responses for the four discriminators (in Table 1), are shown in Figure 10. All four have transient response of a second order system, although the BOC-PRN (direct prompt) and BOC-BOC (Dot Product E-L) discriminators have very short settle time compared to the other two. In this experiment, in order to have a fair comparison among BOC-BOC (Normalized and Dot Product E-L) and BOC-PRN (E+L), the combined gain(i.e. K_{ld}) of the Loop filters are set to be the same($K_{ld}=5$). According to Figure 11, BOC-BOC (Normalized E-L) has a longer settle time than the others; while the BOC-BOC (Dot Product) has the shortest.

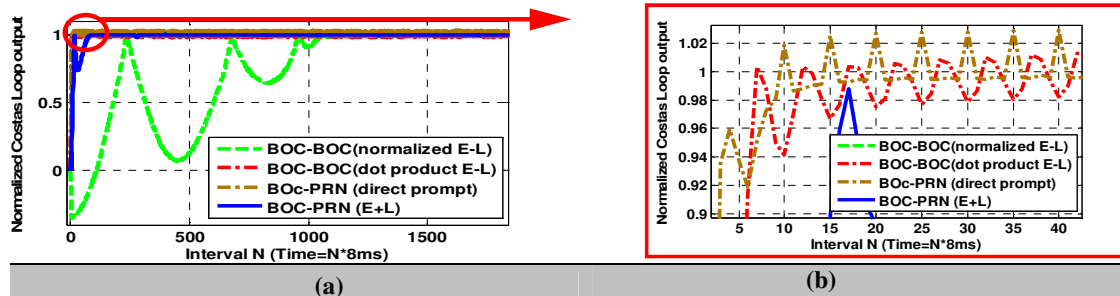

Figure11 Normalized Transient Responses of Costas Loop utilizing different Delay lock loop discriminators(a) & the zoom of (a) showing BOC-BOC(Dot Product E-L) & BOC-PRN(direct prompt) To compare the accuracy of three discriminators (BOC-BOC (Normalized and Dot Product E-L) and BOC-PRN (E+L)) in terms of C/No, PLL and DLL phase error, another set of simulated signals is used which has modulated the S-code and C-code with subcarrier and

carrier (Doppler Effect is considered). The tracking loop settings are shown in Table1 where this signal is marked as “*”. Before the signal is applied to the combined tracking loop, different amplitudes (0-30 times higher than that of satellite signal “*”) of additive white random noise are combined with the simulated GIOVE-A signal in the C channel. The resulting input S/N (in dB) changes from 0dB to >65dB (supposed the simulated satellite are received from wideband frontend, i.e.40MHz and has the noise floor at -98dBm (-114+10log40) , so S/N=-30db would be equivalent to satellite signal of about -128dBm). The performance comparisons are shown in Figure 12.

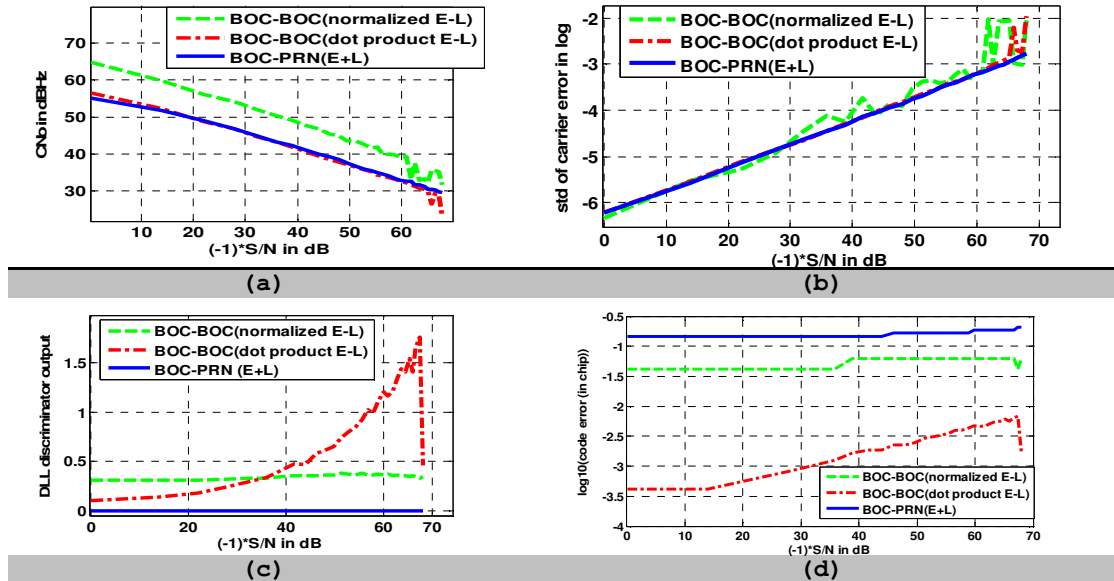

Figure 12 Performance comparison among three discriminators

- (a) Costas Loop output in terms of C/No V.S. varying S/N of input signal
- (b) Standard variation of carrier phase errors [Hz] (in log10 scale)
- (c) Standard Variation of delay lock loop discriminator output
- (d) converted standard deviation of code phase error [chip](in log10 scale)

* The C/No are computed estimator in (Parkinson & Spilker Jr., Eqs. (117), PP.392, 1996)

As can be seen from Figure 12(a), when the tracking loop is locked, the BOC-BOC (Normalized E-L) has the best CNo for different SNR of input signal. Meanwhile, the BOC-BOC (Dot Product E-L) discriminator has a similar trend to the BOC-PRN(E+L) discriminator as expected, although with a high SNR input signal, the first one reacts with slightly higher CNo. This higher CNo is possibly caused by the higher discriminator gain when the code phase error is low due to lower noise power. When the SNR of the input signal decreases below about -60dB, both of the E-L discriminators become unstable and the CNo fluctuates, while the BOC-PRN (E+L) remains stable because of its wider linear operation range on the discriminator function.

When the PLL phase errors (using the same PLL discriminator) are compared, the BOC-BOC (Normalized E-L) has the poorest stability performance and the fluctuation of carrier phase error becomes more and more serious with decreasing of SNR. The BOC-BOC (Dot Product E-L) also has fluctuating carrier phase error when the SNR decreases to about -65dB. The BOC-PRN (E+L) has the most stable performance.

To compare the code phase error from the DLL, there should be a conversion between the actual code error obtained directly from the DLL discriminator output and the ideal discriminator function in the presence of no noise (Figure 5(1),(2) and Figure 5(1)). So that it

can “map” the code phase error (in chips) to the actual code error affected by different scale factors in discriminators expression. Therefore the DLL discriminator outputs (in Figure 12(c)) will convert to code error in chips as shown in Figure 12(d) (where the code errors results in chips have been scaled in log10). It is shown that, as expected, the BOC-PRN(E+L) has higher code phase error in log10 scale (about $-0.8e10$) than that (about $-1.4e10$) of BOC-BOC(Normalized E-L) for about 0.075chip. The BOC-PRN (Dot Product) discriminator has the highest accuracy (in terms of code phase) despite being the fastest type that increases the code phase error when S/N of input signal decreases because of its poorest “linearization” within the operational range which is also proved by the gain function shown in Figure5 B(2). Based on these simulation results, BOC-PRN (E+L) presents a comparable high quality, robust solution with reasonable precision compared with conventional DLL discriminators.

3.2.3 Tracking real satellite signals

A set of real satellite signal data used the loops using BOC-PRN (direct prompt) and BOC-PRN (E+L) discriminators. The settings of the tracking loop are the same for both cases as shown in Table 2.

Discriminator Scale factor	Damping ratio(DLL and PLL)	DLL noise bandwidth	DLL Loop filter Gain K_0	PLL noise Bandwidth	PLL Loop filter Gain K_{1p}	Integration Time T
300e2	0.7	10 Hz	1.4	30 Hz	2.5	0.008 Sec

Table 2 Costas Lock Loop setting for Real satellite Intermediate Frequency (IF) raw signal

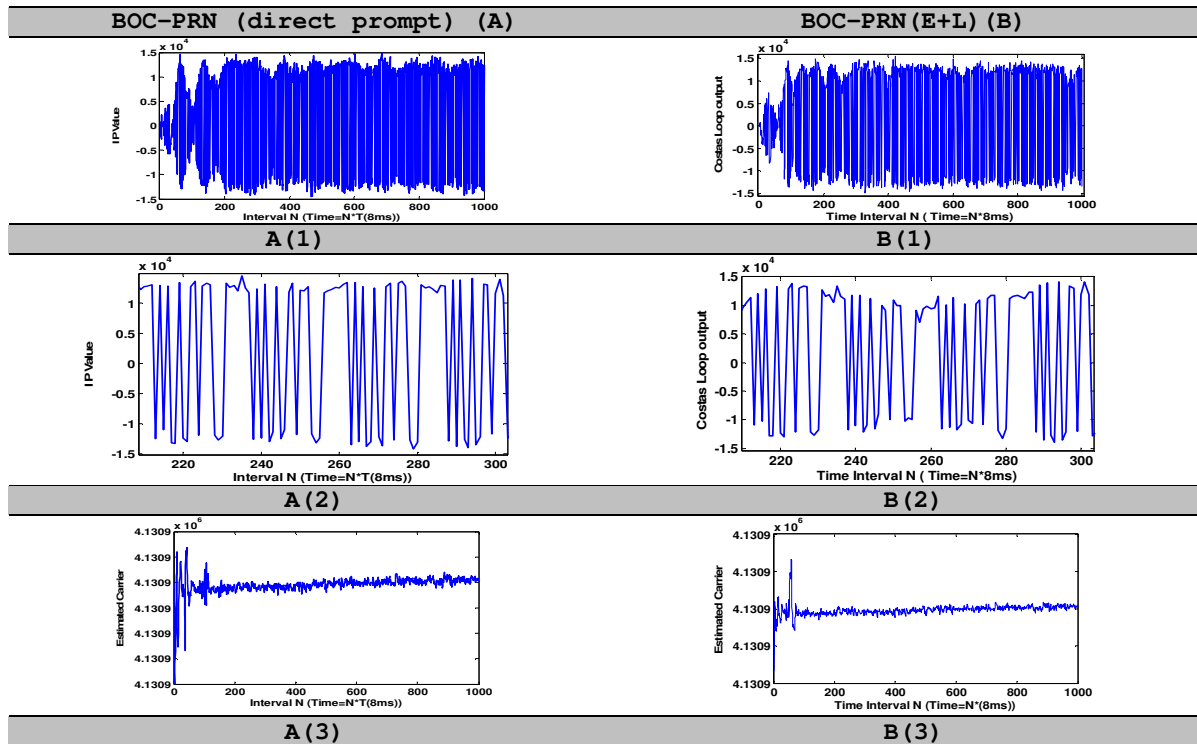

Figure 13 Real data tracking: plot of Pilot Channel Costas Loop output in time domain (updating intervals) (from SIGE Frontend(at 30March07,data1) Using BOC-PRN discriminators)
A)BOC-PRN(Direct Prompt)discriminator; B)BOC-PRN(E+L)discriminator
A/B(1)Costas Loop output (Navigation bit-secondary code in pilot channel);(2) zoom in on (1) between 220 and 300 integration intervals ;(3) Estimated carrier (around intermediate frequency of 4130400Hz).

The loop outputs for both cases are shown in Figure 13. The BOC-PRN (E+L) shows a slightly shorter settle time than BOC-PRN (direct prompt) (shown in Figure 13 A(1) and

B(1)); while the extracted S- code has a similar pattern(shown in Figure 13 A(2) and B(2)) when the same update intervals of the tracking loop are used. Figure 13 A (3) and B(3) illustrate the carrier estimation for combined tracking loop and they also shown that BOC-PRN(E+L) is easier to control and settles down more quickly than BOC-RPN(direct prompt) due to higher gain of discriminator function.

The converted “navigation bits” (in BPSK form) from 226 to 250 intervals is shown in Table 3. The extracted “navigation bits” can be seen to match the S-code given by the ICD of GIOVE-A (Galileo Project Office of European Space Agency, 2007) so the loop can successfully extract navigation data bit although they present a different pseudorange accuracy as discussed in section 3.22.

CS25a (2007, GIOVE-A ICD)	0 0 1 1 1 0 0 0 0 0 0 0 1 0 1 0 1 1 0 1 1 0 0 1 0 [B]
Output (226:250)	1 1 -1 -1 -1 1 1 1 1 1 1 -1 1 -1 1 -1 1 -1 -1 1 1 -1 1 [BPSK]

Table 3 Navigation bit(from Costas Loop output)&Published secondary code

CONCLUSIONS

In this paper, acquisition of the GIOVE-A signal using the UNSW FPGA GNSS receiver “Namuru” and other receivers is discussed. The ACFs are obtained using real satellite signals recorded in the SNAP lab at UNSW. For signal tracking loop design, DLL techniques are analysed. Among those implementations, an Extended BOC-PRN (BOC-PRN (direct prompt)) method and a novel BOC-PRN (E+ L) method are presented and compared. Finally, offline tracking results for recorded satellite signals applying these two methods are illustrated.

The new DLL discriminator can preserve both signal performance, in terms of relative high robustness, good signal sensitivity and steep slopes of the discriminator function, while maintaining efficient hardware/software architecture. Furthermore, the BOC-PRN (E+L) discriminator has embedded a multipath rejection property so that it also has the possibility of maintaining the multipath mitigation features of BOC (1, 1) liked a Narrow Correlator. Future work will further analyse the multipath property of the new discriminator, design its normalization expression; and implement the design in real-time on “Namuru” for a hybrid GPS/Galileo receiver design.

ACKNOWLEDGEMENTS

This piece of research work is funded under ARC Discovery project DP0556848.

REFERENCES

- Galileo Project Office of European Space Agency. (2007, March 2). *GIOVE: Galileo In-orbit Validation Element*. Retrieved March 6, 2007, from EESA: http://www.giove.esa.int/images/userpage/GIOVEA_SISICD.pdf
- Balaei, A. T., Wu, J., & Dempster, A. (2007). Comparison between GPS and Galileo satellite availability in the presence of CW interference. *To be published in IGNSS Symposium 2007*. Sydney, Australia: International Global Navigation Satellite Systems Society.
- Borre.Kai, Akos, D. M., Bertelsen, N., Rinder, P., & Jensen, S. H. (2006). A Software-Defined GPS And Galileo Receiver-A Single-Frequency Approach. PP.93-94,New York,USA: Springer.

- Castro, David de; Diez, Jose; Fernández, Antonio; Sleewaegen, Jean-Marie. (2006). A New Unambiguous Low-Complexity BOC Tracking Technique. *ION GNSS 19th International Meeting of the Satellite Division*. Fort Worth, TX.
- Van Dierendonck, A.J., Fenton, P., & Ford, T. (1992). Theory and Performance of Narrow Correlator Spacing in a GPS Receiver. *Journal of The Institute of Navigation* , V.39, No.3 USA.
- Dovis, Fabio; Mulassano, Paolo; Presti, Letizia Lo. (2005). A Novel Algorithm for the Code Tracking of BOC(n,n) Modulated Signals. *ION GNSS 18th International Technical Meeting of the Satellite Division*. Long Beach, CA.
- Fante, R. L. (2003). *Unambiguous Tracker for GPS Binary-Offset-Carrier Signal*. MITRE Corporation technical report.
- Fine, P., & Wilson, W. (1999). Tracking Algorithm for GPS Offset Carrier Signal. *Proceedings of the ION 1999 National Technical Meeting* (pp. 671-676). Institute of Navigation National.
- Garin, L. J. (2005). The "Shaping Correlator", Novel Multipath Mitigation Technique applicable to GALILEO BOC(1,1) Modulation Waveforms in High Volume Markets. *The European Navigation Conference GNSS 2005*. Munich, Germany.
- Gerein, N., Olynik, M., & Clayton, M. (2004). Galileo BOC(1,1) Prototype Receiver Development. *Proc of ION GNSS*. Long Beach, CA.
- Kovář, Pavel; Vejražka, F.; Seidl, L.; Kačmařík, P. . (2004). Galileo Receiver Core Technologies. *The 2004 International Symposium on GNSS/GPS*. Sydney, Australia.
- Martin, N.; LeBlond, V.; Guillotel, G.; Heiries, V. (2003). BOC(x,y) signal acquisition techniques and performances. *Proceedings of the ION-GPS/GNSS 2003*. Portland, OR: Institute of Navigation.
- Montenbruck, O., Günther, C., Graf, S., Garcia-Fernandez, M., Furrner, J., & Kuhlén, H. (2006). GIOVE-A initial signal analysis. *GPS Solutuion*, vol 10, no 2, , 146–153.
- Novatel Inc., N. (2000, Feb 1st). *Discussions on RF Signal Propagation and Multipath*. Retrieved June 29, 2007, from Novatel: <http://www.novatel.com/Documents/Bulletins/apn008.pdf>
- Nunes, F.; Sousa, F.; Leitão, J. (2004). Innovation-based Code Discriminator for GPS/Galileo BOC Signals. *IEEE* , 4127-4131.
- Parkinson, B., & Spilker Jr., J. (1996). *Global Positioning System: Theory and Application*. Washington: Progress in Astronautics and Aeronautics.
- Psiaki, M. L., Humphreys, T. E., Mohiuddin, S., Powell, S. P., Cerruti, A. P., & Kintner Jr., P. M. (2006). Searching for Galileo -Reception and Analysis of Signals from GIOVE-A. *GPS World*, 1st, June , pp66-72.
- Qaisar, S. U.; Wu, J.; Dempster, A.G. (2007). Load and Clear : Receiving the new GPS L2C and Galileo signal. *Position* , June-July, pp. 58-60.
- Ward, P. (1996). Satellite Signal Acquisition and Tracking. In K. E.D., *Understanding GPS Principles and Application* (pp. 119-208). Boston: Artech House.